

CA 1017 Thermokoppel met verschuifbare montageflens

Beschermbuis

Constructie	Gesloten buis, diameter Ø 9 mm
Materiaal	RVS 316 - (Wst 1.4401)
Insteeklengte "L"	Te specificeren
Procesaansluiting	Verschuifbare flens
Flensmaat	Diameter 55 mm

Aansluitkop

Model	"B", volgens DIN 43729
Materiaal	Aluminium
Kabel ingang	M20 x 1,5 kabelwartel

Meetinzet

Type	MI 1025
Constructie	Verend en uitwisselbaar
Diameter	Ø 6 mm
Lengte "E"	E = L + 35 mm
Materiaal	RVS 316 - (Wst 1.4401)

Thermokoppel

Kalibratie	K, T, J, E, N, U of L
Voor duplex	KK, TT, JJ, EE, NN, UU of LL
Nauwkeurigheid	Volgens IEC 60584 klasse1

Opties

Transmitter 4-20mA	Koptransmitter, standaard of ATEX Explosie veilig. Kies uit ons standaard assortiment, zie "Transmitter" hoofdstuk, specificeer merk, model en bereik
Klapdeksel aansluitkop	DAN. Transmitter direct gemonteerd op het meetinzet
Hoge klapdeksel kop	DAN-H. Transmitter in de deksel. Meetinzet verwisselbaar

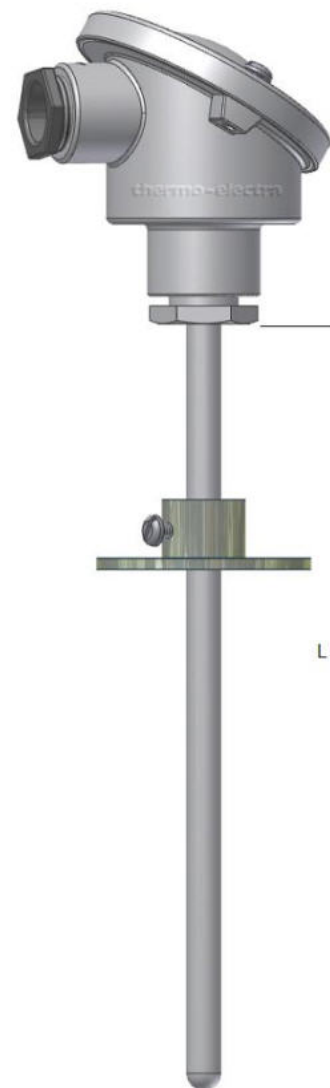

Thermokoppel kleurcodes

Thermocouple Extension Type	ANSI	IEC
JX + Iron - Constantan ®		
KX + Chromel ® - Alumel ®		
TX + Copper - Constantan ®		
EX + Chromel ® - Constantan ®		
NX + Nicrosil ® - Nisil ®		
SX + Copper RX - Alloy 11		
BX + Copper-S - Copper-E		

Toleranties volgens IEC 584-2

Type	Class	Temperature range	Fixed value °C	Tolerance to temp. t (°C)
T	1	- 40°C to + 350°C	± 0,5	± 0,004 · t
	2	- 40°C to + 350°C	± 1	± 0,0075 · t
	3	- 200°C to + 40°C	± 1	± 0,015 · t
E	1	- 40°C to + 800°C	± 1,5	± 0,004 · t
	2	- 40°C to + 900°C	± 2,5	± 0,0075 · t
	3	- 200°C to + 40°C	± 2,5	± 0,015 · t
J	1	- 40°C to + 750°C	± 1,5	± 0,004 · t
	2	- 40°C to + 750°C	± 2,5	± 0,0075 · t
	3	-	-	-
K and N	1	- 40°C to + 1000°C	± 1,5	± 0,004 · t
	2	- 40°C to + 1200°C	± 2,5	± 0,0075 · t
	3	- 200°C to + 40°C	± 2,5	± 0,015 · t
R and S	1	0°C to + 1600°C	± 1,0	± [1+0,003 ·(t-1100)]°C
	2	0°C to + 1600°C	± 1,5	± 0,0025 ·t
	3	-	-	-
B	1	-	-	-
	2	+ 600°C to + 1700°C	± 1,5	± 0,0025 ·t
	3	+ 600°C to + 1700°C	± 4	± 0,005 ·t

Ordering code

*This datasheet is purely indicative, build-up of model code may vary from this datasheet.

